

Ramp Roller Bolt-On Kit (Pair)

Instructions

Part #: 1006695

Parts List			
ITEM	QTY	PART NUMBER	DESCRIPTION
1	2	-	Ramp Sold Separately
2	2	1005726	6 IN UHMW ROLLER
3	4	1002565	WASHER FLAT 1/2 SS
4	2	1001795	NUT 1/2 NYLOC BRASS
5	2	1002395	Bolt Hex 1/2-13 x 8.0 SS 304
6	4	1002599	WASHER FLAT 3/8 SS
7	4	1001802	Nut Hex 3/8-16 Brass
8	4	1001963	3/8" x 4.0" S.S. Carriage Bolt
9	2	1003734	Bolt-On Roller Bracket

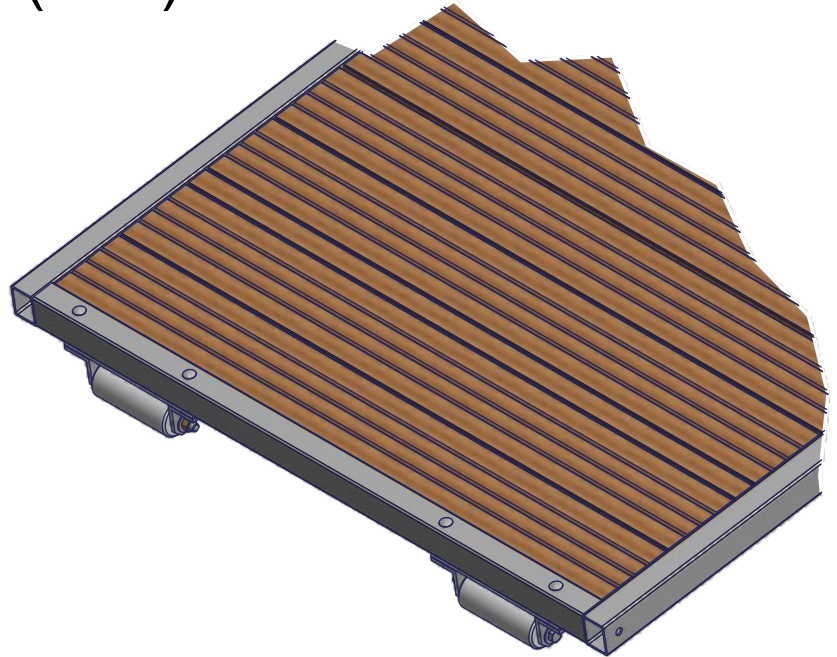

Failure to follow instructions may result in personal injury and may invalidate the applicable warranty.

⚠ CAUTION To avoid personal injury use caution when drilling bolt holes. Don't wear loose hanging clothing or jewelry when operating the drill. Keep out of the way of the drill bit.

Step 1. Position bolt-on roller bracket on bottom side of ramp set in from the side of the ramp about 3". Mark the two holes and drill through ramp tube using a 7/16" drill bit.

Step 2. Insert 3/8 carriage bolts from the top through previously drilled holes in ramp, and through bolt-on roller bracket and secure with 3/8 flat washers and 3/8 brass hex nuts.

Step 3. Attach rollers to bolt-on roller bracket and secure with 1/2 x 8 hex bolt, 1/2 flat washer, and 1/2 brass nyloc nut.

